

S3006P/3008P/3010P

PUSH-AROUND MINI SCISSOR LIFTS



- Lightweight and compact
- Easily passes through a standard doorway
- No outriggers or stabilisers required
- Durable design for tough site conditions
- Proven benefits over other low level access products:
 - better job site productivity
 - safer and more convenient working conditions
 - better return on investment (ROI) for rental/hire companies

snorkel
www.snorkellifts.com

PUSH-AROUND MINI SCISSOR LIFTS

S3006P 3008P/3010P

DIMENSIONS	S3006P	S3008P	S3010P
Max. working height	4.0m	4.5m	5.0m
Max. platform height (A)	2.0m	2.5m	3.0m
Platform size (outside)	1.1m x 0.52m	1.1m x 0.52m	1.1m x 0.52m
Overall width (B)	0.75m	0.75m	0.75m
Overall length (C)	1.2m	1.2m	1.2m
Stowed height (D)	1.7m	1.8m	1.8m

PERFORMANCE

Platform capacity (SWL)	240kg	240kg	240kg
Max. wind speed	0m/s	0m/s	0m/s
Raise/lower time	8/14 sec	13/17 sec	19/26 sec

POWER

Power source	12V DC battery
Charger	Built in multi-voltage (90V - 240V)

WEIGHT

Weight	310kg	350kg	370kg
--------	-------	-------	-------

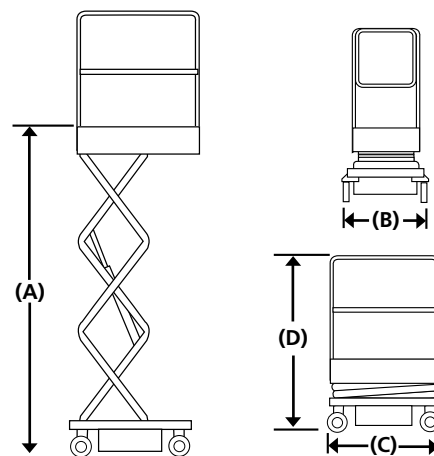

STANDARD FEATURES

- Auto brake system
- Tilt sensor
- Saloon-door style entry gates
- Integrated battery charger 90V-240V
- Battery charge indicator
- Forklift pockets
- Emergency lowering system
- Non-marking casters
- Slide-out service trays
- 2 year parts & labour, 5 year structural warranty
- CE approved

OPTIONS

- Special paint colours
- Environmental hydraulic oil

PLATFORM HEIGHTS

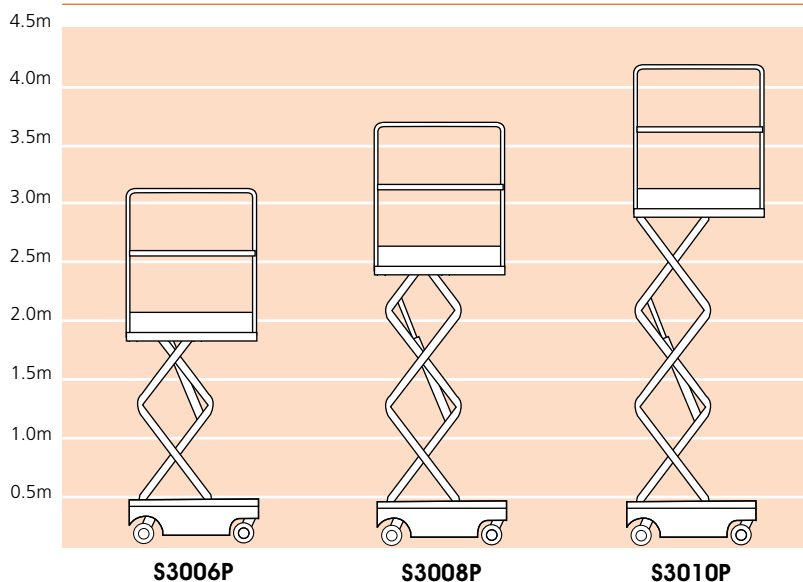

snorkel www.snorkellifts.com

Vigo Centre, Birtley Road,
Washington, Tyne & Wear,
NE38 9DA, U.K.

t: +44 (0) 845 1550 057
e: sales.emea@snorkellifts.com